



# VECTOR™

## **Flexible System for Deburring and Polishing:**

The Extrude Hone VECTOR™ Series Abrasive Flow Machining (AFM) system is extremely flexible and capable of polishing large extrusion and forming dies, deburring and polishing precision parts in small batch quantities or medium to large volume production.

A wide range of available media cylinder diameters offer a broad choice of pressure ranges to meet specific production requirements. The VECTOR series features an ergonomic, user-friendly design that is easy to maintain. A broad work table accommodates large, bulky and heavy components.

A standard feature on the VECTOR series is a PLC – monitoring and saving all major processing data. An easy-to-use touchscreen operator interface makes standard machine functions clear and simple and allows input of processing parameters.



## **System Features at a Glance:**

- **Individually configurable AFM system**  
*Various options create a tailor-made system.*
- **Ergonomic and user-friendly**  
*Ease of use and reduced worker fatigue.*
- **Fast set-up and change of media**  
*Generously dimensioned machining area for large workpieces and rapid tool change.*
- **Controlled production**  
*State-of-the-art control system stores and monitors all major process data.*
- **All process data at a glance**  
*Touch screen interface for easy operation and setup.*
- **Ease of automation and integration in production lines**  
*Defined interfaces are available as an option.*

# Technical Data AFM VECTOR Series

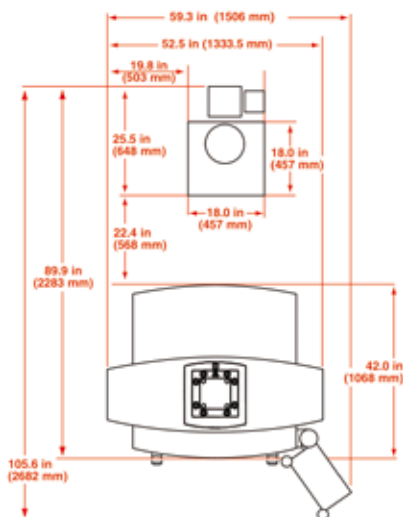

## Machine Specifications

VECTOR series Abrasive Flow Machine consists of a machine base with covers, and a tabletop.

|  |            |
|--|------------|
| Height fully open                      | 2,590.8 mm |
| Height closed                          | 2,336.8 mm |
| Width                                  | 1,333.5 mm |
| Depth                                  | 1,066.8 mm |
| Tabletop height                        | 1,041.4 mm |
| Working distance between clamp columns | 914.4 mm   |
| Estimated weight                       | 1,955 kg   |

## Media Delivery

Media delivery is reciprocating between the top and bottom Assemblies. Both assemblies consist of media cylinders, pistons, seals and caps.

## Hydraulic Specifications

Main components of the hydraulic system are a hydraulic power unit, two media hydraulic cylinders, and two clamp cylinders with an air/oil pump assist.

## Standard Power Unit

|                           |                |
|---------------------------|----------------|
| Reservoir                 | 75.7 l         |
| Pump capacity @ 1,750 rpm | 18.9 l/min     |
| Pressure                  | 23.8 - 102 bar |

## Clamp Cylinders

(Clamping is powered hydraulically)

|                 |        |
|-----------------|--------|
| Bore diameter   | 127 mm |
| Stroke          | 508 mm |
| Maximum opening | 560 mm |
| Minimum opening | 51 mm  |

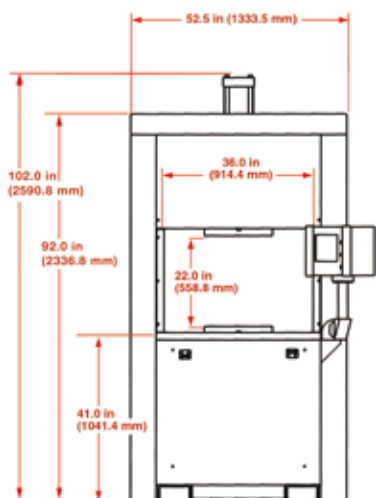

## Electrical Specifications

The machine is controlled by a PLC. The operator interface terminal is a touch screen. Standard functions include remote media pressure adjustment, automatic and manual mode, displacement counter, cycle counter, and cycle timer. The machine process parameters are preset via the operator interface terminal and can also be monitored on the terminal once the automatic cycle has been initiated.

## Electrical

|               |                 |
|---------------|-----------------|
| Voltage       | 400 VAC / 50 Hz |
| Motor         | 3.75 kW         |
| Peak amperage | 9.5 Amps        |

## Controls

|                                      |                 |
|--------------------------------------|-----------------|
| Standard controller                  | Siemens S7-200* |
| * other controls available as option |                 |

## Fluid Connection Specifications

### Hydraulic

|           |         |
|-----------|---------|
| Ports     | SAE     |
| Hose/Tube | 37° JIC |

### Water

|           |          |
|-----------|----------|
| Ports     | NPT      |
| Hose/Tube | Push Lok |

### Pneumatic

|           |          |
|-----------|----------|
| Ports     | BSPB     |
| Hose/Tube | Push Lok |

## Accessories / Options

- Sliding table
- Fixture cart
- Media heater and cooler
- Separate media delivery
- Blow-off station
- Advanced Autoflow
- Real time display of media piston position

## SYSTEM CONFIGURATIONS

|                   | VECTOR Series           |                             |                     |                |                     |                 |                     | VECTOR High-Pressure   |                         |                        |                         |
|-------------------|-------------------------|-----------------------------|---------------------|----------------|---------------------|-----------------|---------------------|------------------------|-------------------------|------------------------|-------------------------|
|                   | Media Cylinder Diameter | Hydraulic Cylinder Diameter | Media Stroke Length | Media Capacity | Hydraulic Flow Rate | Media Flow Rate | Standard Power Unit | min/max Media Pressure | max* Expansion Diameter | min/max Media Pressure | max* Expansion Diameter |
| <b>Vector 100</b> | 100 mm                  | 150 mm                      | 320 mm              | 2.6 l          | 18.9 l/min          | 8.3 l/min       | 3.73 kW             | 53 / 204 bar           | 127 mm                  | N/A                    | N/A                     |
| <b>Vector 150</b> | 150 mm                  | 150 mm                      | 320 mm              | 5.8 l          | 18.9 l/min          | 19 l/min        | 3.73 kW             | 24 / 102 bar           | 188 mm                  | 24 / 163 bar           | 165 mm                  |
| <b>Vector 200</b> | 200 mm                  | 150 mm                      | 320 mm              | 10.3 l         | 18.9 l/min          | 33.3 l/min      | 3.73 kW             | 13.6 / 61 bar          | 252 mm                  | 13.6 / 98 bar          | 221 mm                  |
| <b>Vector 250</b> | 255 mm                  | 150 mm                      | 320 mm              | 16.1 l         | 18.9 l/min          | 53 l/min        | 3.73 kW             | 8.5 / 41 bar           | 312 mm                  | 8.5 / 65 bar           | 277 mm                  |
| <b>Vector 300</b> | 305 mm                  | 200 mm                      | 320 mm              | 23.2 l         | 18.9 l/min          | 76 l/min        | 3.73 kW             | 6 / 25.5 bar           | 376 mm                  | 6 / 41 bar             | 333 mm                  |

\*Maximum expansion diameter at maximum media pressure

All machines in this series comply with the applicable EU Directives governing machine safety and bear the CE mark. They also comply with accident prevention regulations and the VDE and VDI regulations, as well as the requirements concerning electromagnetic compatibility.

Subject to technical changes serving to improve the system and in line with technological progress.



More information about finishing equipment...

**Extrude Hone GmbH**  
 Berghäuser Strasse 62  
 D-42859 Remscheid  
 Tel. +49 2191-900-250  
 Fax +49 2191-900-254  
 remscheid.information@kennametal.com  
[www.extrudehone.com](http://www.extrudehone.com)

**Extrude Hone GmbH**  
 Memminger Strasse 37  
 D-87746 Erkheim  
 Tel. +49 8336-8005-0  
 Fax +49 8336-8005-500  
 erkheim.information@kennametal.com  
[www.extrudehone.com](http://www.extrudehone.com)

